

EN

COMAU

Racer-5

COBOT



Racer5
COBOT

Comau HUMANufacturing

Collaboration is the new automation

Industry 4.0. The factory is changing to become a network of flexible, modular and scalable automation systems that are capable of operating autonomously or in a secure synergistic way with operators, always connected and under control.

As a world leader in advanced automation solutions, Comau has always improved manufacturing scenarios through up-to-date and human-centric technologies, capable of enhancing the social and environmental sustainability of the workplaces.

Automation is no longer confined within barriers, but it collaborates with human beings: this is what we like to call Comau HUMANufacturing, the new concept of human-machine collaboration.



Discover Racer-5-0.80 COBOT

Features

- 5 Kg payload
- 0.809 m reach
- 0.03 mm repeatability
- Cobot SAFE version controller
- Up to 6 m/s cartesian speed in non-collaborative mode
- Safe Collision Detection function - PL d CAT. 3 certified by TÜV Süd

Benefits

- High repeatability and accuracy
- Racer-5 Industrial robot speed when no human operator near by for an increased productivity
- Electrical and air connections near the wrist avoiding external harness
- Immediate awareness of cobot status due to LED stripe
- Efficiency and flexibility of the cycle
- Reduction of spaces for automation
- Simplified process inspection and quality control

Racer-5-0.80 COBOT supports humans as they perform manual operations, by optimizing the work process.



LED strip for COBOT status

GREEN: collaborative mode
Blinking Green: manual guidance mode or programming mode.

BLUE: manual restart after collision
Blinking BLUE: automatic restart after collision.

RED: System alarm

NO LED: full speed mode



Full speed mode is dynamically managed, when collaboration is not required

FULL - COLLABORATIVE SPEED SWITCH (Controller option + Safety device installed)

- Collaborative speed: up to 500 mm/s (Compliant to ISO/TS 15066 - Tested by Tuv Rheinland)
- Full Speed: like a standard Racer-5 robot



Technical features

VERSION		Racer-5-0.80 COBOT
Structure / No. of axes		Anthropomorphic / 6 axes
Maximum wrist load		5 kg
Nominal wrist load		1 kg
Axis 4 torque		8,83 Nm
Axis 5 torque		8,83 Nm
Axis 6 torque		4,91 Nm
Admissible inertia on axis 4*		0,42 kg x m ²
Admissible inertia on axis 5*		0,42 kg x m ²
Admissible inertia on axis 6*		0,18 kg x m ²
Stroke /(Max Speed)	Axis 1	+/- 170° (360 °/s) **
	Axis 2	-64° / +114° (300 °/s) **
	Axis 3	-150° / +60° (330 °/s) **
	Axis 4	+/- 200° (500 °/s) **
	Axis 5	- 105°/ +100° (500 °/s) **
	Axis 6	+/- 2700° (800 °/s) **
Max horizontal reach		809 mm
Repeatability		+/- 0,03 mm
Robot weight		34 kg
Features of the tool coupling Robot wrist		ISO 9409 - 1 - A 25
Motors		AC Brushless
Position measurement system		Encoder
Protection degree		IP54
Mounting position		Floor
Operating environment temperature		5°C / +40°C
Storage temperature		-10°C / 55°C
Relative humidity		from 5% to 95% without condensation
Maximum temperature gradient		1,5 °C/min

* Not allowed with maximum load
 ** Maximum speed
 *** Base vertical cable output available (option)

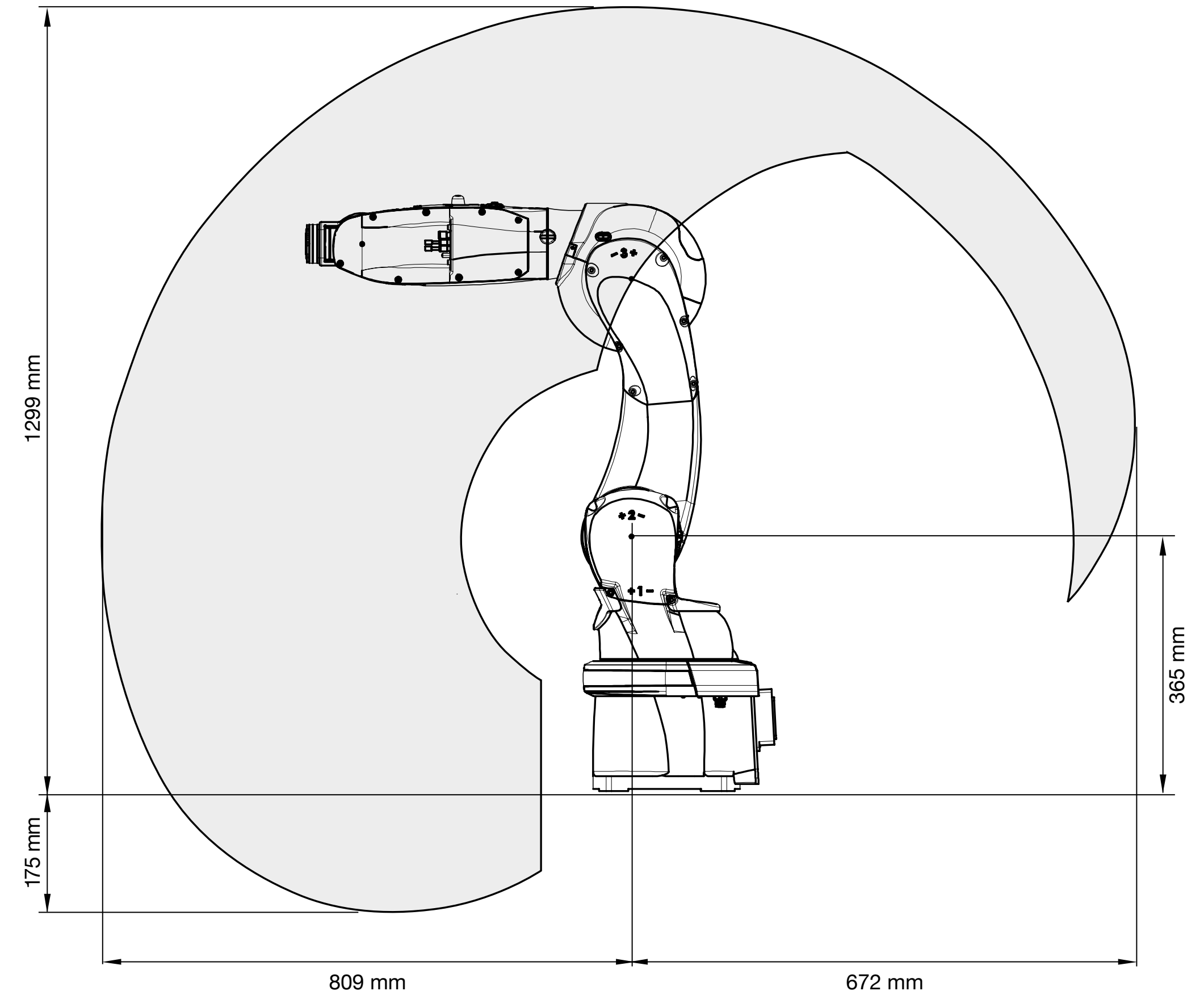



robotics.comau.com

Follow us



The contents of this brochure are supplied for general information only. Comau S.p.A. reserves the right to alter specifications at any time without notice for technical or commercial reasons. The illustration does not necessarily show the products in their standard version. Edition - 03/21 - Turin

Made in Comau